



Item # \_\_\_\_\_

# RCOS Gas Convection Oven

## STANDARD FEATURES:

- ◆ Standard Depth, accomodates full size Sheet Pans side to side.
- ◆ 35,000 BTU burners, 2 per oven, for rapid heat up and recovery
- ◆ ENERGY STAR® certification for reduced energy costs.
- ◆ Electric thermostat adjustable from 150° to 500° F.
- ◆ Two speed motor to select best air circulation for desired results.
- ◆ Air deflectors strategically placed around the blower for efficient air circulation.
- ◆ Cool Touch Controls set back for protection.
- ◆ Electronic ignition with 100 % safety.
- ◆ Glass Window in the right hand door next to controls with two interior lights let the chef easily observe food product.
- ◆ Oven interior is porcelain coated for protection from spills.
- ◆ Both doors feature stainless steel interior and exterior for durability and ease in cleaning.
- ◆ Oven doors swing open 135 degrees for easier access for loading and removing pans.
- ◆ 5 Chrome plated racks standard with 11 positions.
- ◆ All S/S Front, sides and Top construction.
- ◆ Unique Stackable design requiring no additional flue extensions.



RCOS-1 Shown  
With Optional  
Rack Guides,  
Racks, and Casters

## OPTIONS:

- ◆ Stainless Steel Bottom Shelf/Stand (Single Deck ovens only).
- ◆ Extra Rack Storage (Single Deck ovens only).
- ◆ Stacking Kit to stack (2) Single Deck units (includes 6" legs).
- ◆ Heavy Duty Casters, Set of 4 (2 locking, 2 non locking).
- ◆ Extra Oven Racks.
- ◆ Glass View Door for Left Side (right side is standard).
- ◆ Direct Connect Vent Kit

*Royal Convection Ovens are engineered for outstanding performance, long life and maximum value. They are constructed with a rugged interior frame, stainless steel sides, top and front. The interior surfaces are porcelain coated for durability and easy cleaning. The ample oven chamber accomodates full size sheet pans. Unlike many other brands we include as standard a glass viewing door on the right, adjacent to the controls for easier regulation while monitoring the food product inside. In addition, our unique design permits stacking two single ovens in the field with simple tools and requires no additional flue exhaust kit.*

ROYAL RANGE OF CALIFORNIA, INC.  
3245 CORRIDOR DRIVE, EASTVALE, CA 91752  
(800) 769-2414 in the U.S. (951) 360-1600 Fax: (951) 360-7500  
www.royalranges.com E-mail: royalrange@dslextreme.com  
PRINTED IN THE U.S.A. (08/11)



# RCOS Convection Oven Specifications

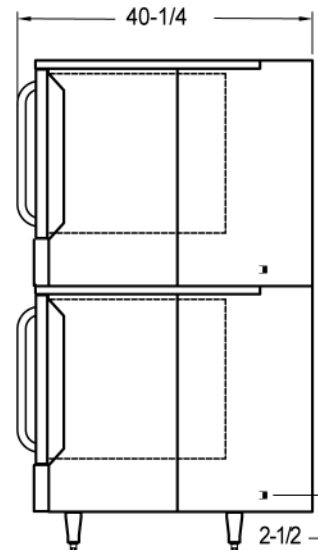
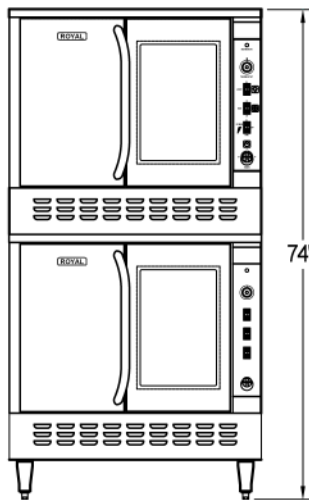
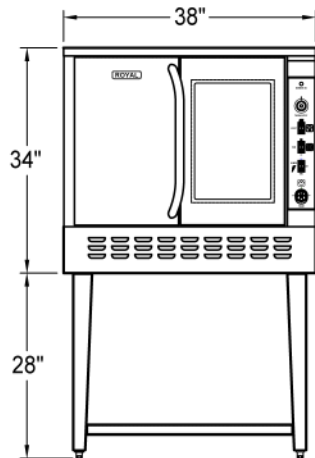
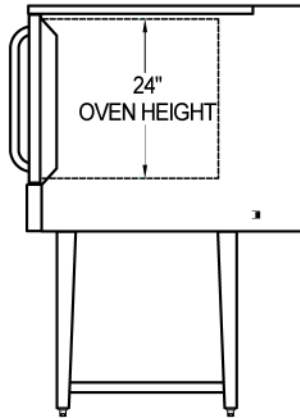
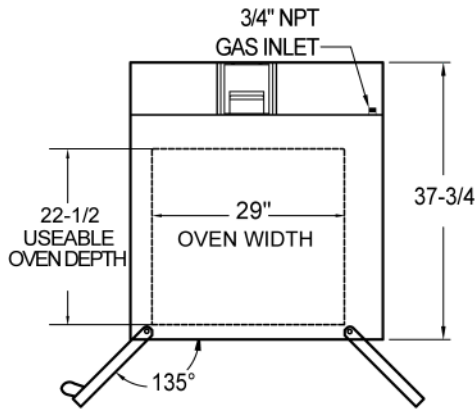

MODEL NO.	WIDTH	DEPTH	NUMBER * OF BURNERS	TOTAL BTU	SHIP WEIGHT
RCOS-1	38"	40-1/4"	2	70,000	520 Lbs.
RCOS-2	38"	40-1/4"	4	140,000	1005 Lbs.
* Note: 35,000 BTU/Hr. each burner.					

**Electrical requirements:** 120VAC, 50-60hz, Single phase.

8 amps per oven (single).

Two speed motor (1725 / 1140 RPM), 1/2 HP.

Provided with 6' power cord fitted with a standard three prong grounded plug.

**Gas Connection:** 3/4" NPT on the right hand rear of the appliance

Gas pressure: 5" W.C. - Natural Gas

The pressure regulator (supplied) is to be connected here by the installer.

10" W.C. - Propane

**Combustible Clearances:**

6 inches sides

6 inches rear

**Non-combustible Clearances:**

0 inches sides

0 inches rear

Specify type of gas and altitude, if over 2,000 feet, when ordering.

*Due to continuing product development to ensure best possible performance, these specifications are subject to change without prior notification*

ROYAL RANGE OF CALIFORNIA, INC. 3245 CORRIDOR DR. EASTVALE, CA 91752 [www.royalranges.com](http://www.royalranges.com)

(800) 769-2414, in the U.S. (951) 360-1600, Fax: (951) 360-7500, E-mail: [royalrange@dslextreme.com](mailto:royalrange@dslextreme.com) PRINTED IN THE U.S.A. (08/11)