



H-600 MIXER

HOBART

STANDARD FEATURES

- 2 H.P. Hobart Designed Fixed Speed Motor
- Gear-Driven Transmission
- 15 Minute Timer
- Four Fixed Speeds
- Open Base
- Large, Easy-To-Reach Controls
- #12 Taper Attachment Hub
- Stainless Steel Bowl Guard
- Manual Bowl Lift
- 60-Quart Stainless Steel Bowl, "B" Flat Beater, "D" Wire Whip, "ED" Dough Hook

ACCESSORIES

- Stainless Steel Bowl
- "B" Flat Beater
- Stainless Steel "B" Beater
- "C" Wing Whip
- "D" Wire Whip
- "E" Dough Hook
- "ED" Dough Hook
- "P" Pastry Knife
- "I" Heavy Duty Wire Whip
- Bowl Extension Ring
- Bowl Splash Cover
- Bowl Scraper
- Bowl Adapter
- Bowl Truck and Bowl Truck Adapter
- 40 and 30 Quart Accessories
- Ingredient Chute
- 9" Vegetable Slicer
- Meat Chopper Attachment

MODELS

- H-600 – 60-Quart All Purpose Mixer
- H-600C – 60-Quart All Purpose Mixer with Maximum Security Correctional Package (200-230/60/3 and 400-460/60/3 only)

OPTIONS

- Electronic Timer (200/60/1 and 200-230/60/3 only)
- Power Bowl Lift (200-230/60/3 only)
- Deluxe Stainless Steel Finish (not available in 115/60/1)

Specifications, Details and Dimensions on Inside and Back.

H-600 MIXER

H-600 MIXER



SOLUTIONS/BENEFITS

2 H.P. Hobart Designed Motor

Durability

- Heavy-duty to meet the most demanding operations

15-Minute Electric Timer

Convenience, Ease of Use, Consistency

- Supports recipe mixing times
- Simplifies operation
- Provides accurate results and eliminates overmixing

Four Fixed Speeds

Flexibility, Reliability, Consistency

- For incorporating, blending, mixing ingredients
- Supports consistent results and thorough mixing

Bowl Guard

Protection

- Safety interlock prevents operation when front portion of guard is out of position

Gear-Driven Transmission

Durability, Reliability

- Ensures consistent performance and minimum downtime with positive drive under heavy loads

Hobart Attachments

Durability, Flexibility

- Hobart manufactured accessories are designed for long-term usage under heavy-duty conditions
- Large array of attachments provide multiple uses for recipe and product processing

H-600 MIXER CAPACITY CHART

Recommended Maximum Capacities - dough capacities based on 70°F. water and 12% flour moisture.

PRODUCT	AGITATORS SUITABLE FOR OPERATION	H-600
CAPACITY OF BOWL (QTS. LIQUID)		60
Egg Whites	D	2 qts.
Mashed Potatoes	B & C	40 lbs.
Mayonnaise (Qts. of Oil)	B or C or D	18 qts.
Meringue (Qts. of Water)	D	1½ qts.
Waffle or Hot Cake Batter	B	24 qts.
Whipped Cream	D or C	12 qts.
Cake, Angel Food (8-10 oz. cake)	C or I	45
Cake, Box or Slab	B or C	50 lbs.
Cake, Cup	B or C	60 lbs.
Cake, Layer	B or C	60 lbs.
Cake, Pound	B	55 lbs.
Cake, Short (Sponge)	C or I	45 lbs.
Cake, Sponge	C or I	36 lbs.
Cookies, Sugar	B	40 lbs.
Dough, Bread or Roll (Lt.-Med.) 60% AR §	ED	80 lbs.*
Dough, Heavy Bread 55% AR §	ED	60 lbs.*
Dough Pie	B & P	50 lbs.
Dough, Thin Pizza 40% AR (max. mix time 5 min.) §‡	ED	40 lbs.□
Dough, Med. Pizza 50% AR §‡	ED	70 lbs.□
Dough, Thick Pizza 60% AR §‡	ED	70 lbs.*
Dough, Raised Donut 65% AR	ED	30 lbs.†
Dough, Whole Wheat 70% AR	ED	70 lbs.
Eggs & Sugar for Sponge Cake	B & C or I	24 lbs.
Icing, Fondant	B	36 lbs.
Icing, Marshmallow	C or I	5 lbs.
Shortening & Sugar, Creamed	B	48 lbs.
Pasta, Basic Egg Noodle (max. mix time 5 min.)	ED	30 lbs.

NOTE: % AR (% Absorption Ratio) - Water weight divided by flour weight. Capacity depends on moisture content of dough. Above capacities based on 12% flour moisture at 70°F water temperature.

□ 1st Speed

* 2nd Speed

† 3rd Speed

§ If high gluten flour is used, reduce above dough batch size by 10%.

‡ 2nd Speed should never be used on 50% AR or lower products.

USE OF ICE REQUIRES A 10% REDUCTION IN BATCH SIZE.

1 gallon of water weighs 8.33 lbs.

NOTE: Attachment hub should not be used while mixing.

SPECIFICATIONS

MOTOR:

2 H.P., Hobart designed, high torque ball bearing, ventilated within mixer enclosure. Single-phase is capacitor-start, induction-run type. Three-phase is polyphase squirrel cage, induction-run type.

Single Phase	115V	19.0 Amps
	200V	10.9 Amps
	230V	9.5 Amps
Three Phase	200-230V	5.8 Amps
	400-460V	3.7 Amps

ELECTRICAL:

115/60/1, 200/60/1, 230/60/1, 200-230/60/3 and 400-460/60/3 – U L Listed. Also available in 220/50/1, 200-220/50/3 and 380-415/50/3 – not submitted for U L Listing.

CONTROLS:

Magnetic contactor with automatic resetting bimetallic thermal overload protection internally mounted. "Start-Stop" push buttons protected by rubber caps. Reduced voltage pilot circuit transformer is supplied for 400-460/60/3 machines. A 15-minute electric timer is standard. Electronic timer control is available at extra cost (200/60/1 and 200-230/60/3 only)

TRANSMISSION:

Gear-driven. Gears are constant mesh heat-treated alloy steel. Anti-friction ball or roller bearings. A hardened steel worm and alloy bronze worm gear transmit power from motor to transmission. All shafts are mounted in ball or roller bearings. Circulating oil lubricant furnished to all gears. Visual type transmission oil level gauge.

SPEEDS:

Four positive speeds -

	Agitator (RPM)	Attachment (RPM)
1. First	71	79
2. Second	123	139
3. Third	206	231
4. Fourth	362	407

BOWL GUARD:

Heavy-duty stainless steel wire front and solid stainless steel rear portion. Front portion of guard rotates easily to add ingredients and install or remove agitator. It detaches in seconds for cleaning in dishwasher or sink. Rear portion of guard can be quickly cleaned in position. Guard must be in closed position before mixer will operate. The bowl support lock prevents the bowl from being lowered while mixer is running. Bowl support interlock provides further protection.

BOWL LIFT:

Hand operated, self-locking in any position.

POWER BOWL LIFT OPTION:

Powered by a 1/3 H.P. motor, the bowl may be raised or lowered by fingertip control through the conveniently located switch. Bowl will remain in position until switch is activated. Available on mixers with the following electrical specifications: 200-230/60/3.

FINISH:

Standard Metallic Gray finish, Polyurethane Enamel. Deluxe stainless steel finish has No. 3 polish on transmission case, bowl support, pedestal, and base (not available in 115/60/1).

STANDARD EQUIPMENT:

Consists of the mixer unit with one (1) 60-quart stainless steel bowl, one (1) "B" flat beater, one (1) "D" wire whip, one (1) "ED" dough hook and stainless steel bowl guard.

ATTACHMENT HUB:

Comes with front-mounted Hobart standard #12 taper attachment hub for use with #12 size attachments.

NOTE: Use of attachment hub during mixing operation may result in a negative impact on performance and longevity of mixer.

ATTACHMENTS AND ACCESSORIES:

The following are available at extra cost:

Stainless Steel Bowl	Bowl Splash Cover
"B" Flat Beater	Bowl Scraper
Stainless Steel "B" Beater	Bowl Adapter
"C" Wing Whip	Bowl Truck and Bowl Truck Adapter
"D" Wire Whip	40 and 30 Quart Accessories
"E" Dough Hook	Ingredient Chute
"ED" Dough Hook	9" Vegetable Slicer
"P" Pastry Knife	Meat Chopper Attachment
"I" Heavy Duty Wire Whip	
Bowl Extension Ring	



Hobart Bowl Scraper



Hobart Ingredient Chute

LISTED BY: Underwriters Laboratories, Inc. and NSF International. Certified by the Baking Industry Sanitation Standard Committee.

H-600 MIXER



SPECIFICATIONS

ELECTRICAL SPECIFICATIONS: 115/60/1, 200/60/1, 230/60/1, 200-230/60/3 and 400-460/60/3 – U L Listed. Also available in 220/50/1, 200-220/50/3 and 380-415/50/3 – not submitted for U L Listing.

WEIGHT: 718 lbs. net; 722 lbs. domestic shipping.

WARRANTY: Unit has full one-year warranty on parts, labor and mileage against manufacturer's defects. Service contracts are available.

DETAILS AND DIMENSIONS

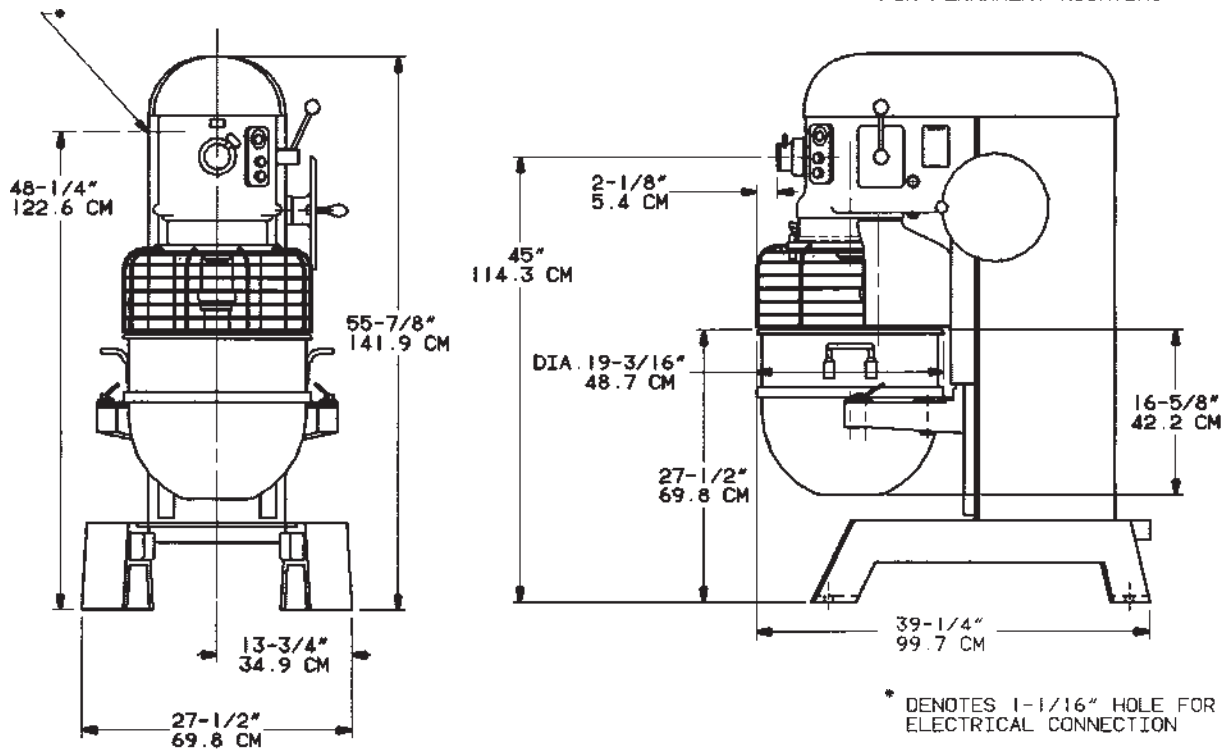
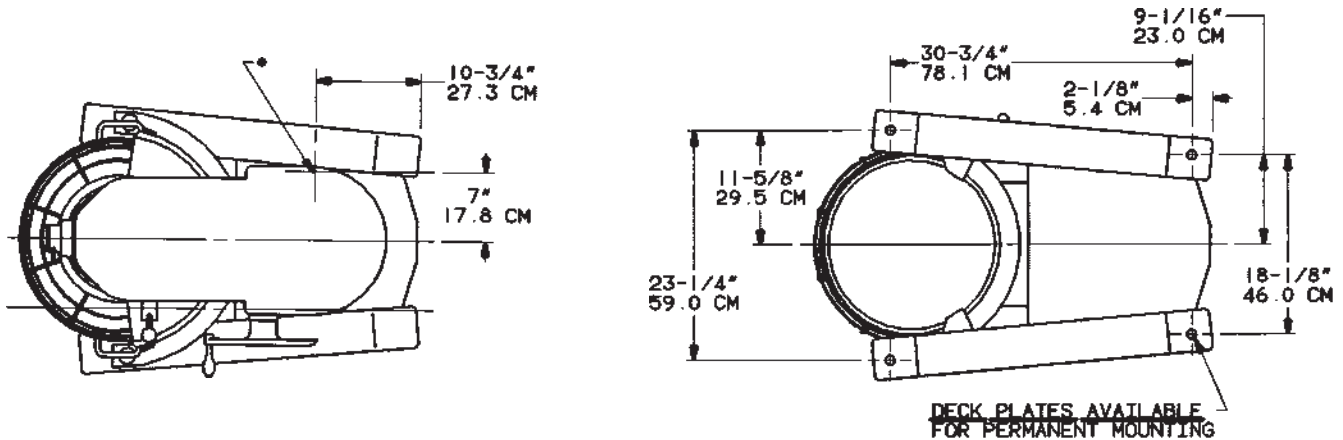

NOTE:
BOLTING TO FLOOR
UNNECESSARY
EXCEPT ON SHIPBOARD

WARNING:
ELECTRICAL AND GROUNDING
CONNECTIONS MUST COMPLY WITH
THE APPLICABLE PORTIONS OF
THE NATIONAL ELECTRICAL CODE
AND/OR OTHER LOCAL ELECTRICAL
CODES.

As continued product improvement is a policy of Hobart, specifications are subject to change without notice.

701 S Ridge Avenue, Troy, OH 45374 • 937-332-3000 • 1-800-333-7447